



14a/16-20 Hereward Street MAROUBRA, NSW



1



1



1

Spacious 1 Bedroom beach side with spectacular views

Peacefully positioned on the 3rd floor and located literally metres from beautiful Maroubra beach, this well presented apartment offers a quality beach lifestyle.

- One bedroom with built in robe
- Light filled living area opens to gorgeous balcony with views
- Modern New kitchen and neat bathroom
- Combined lounge and dining
- Stunning breath taking ocean and district views
- Laundry facilities, lift access
- Easy access car space
- Within moments to public transportation, beach, shops and parkland

Lindy Klein

0412 839 300

Hilary Lazarus

0414 442 414

14A/16-20 Hereward Street, MAROUBRA

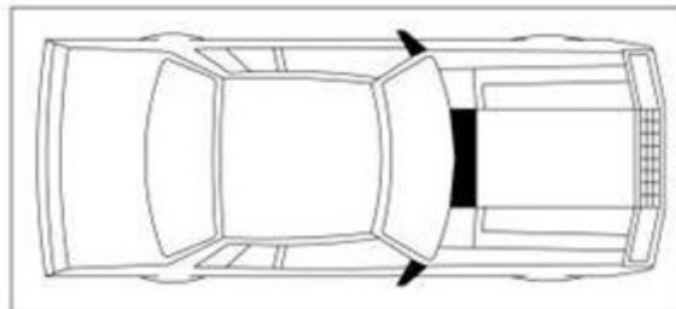
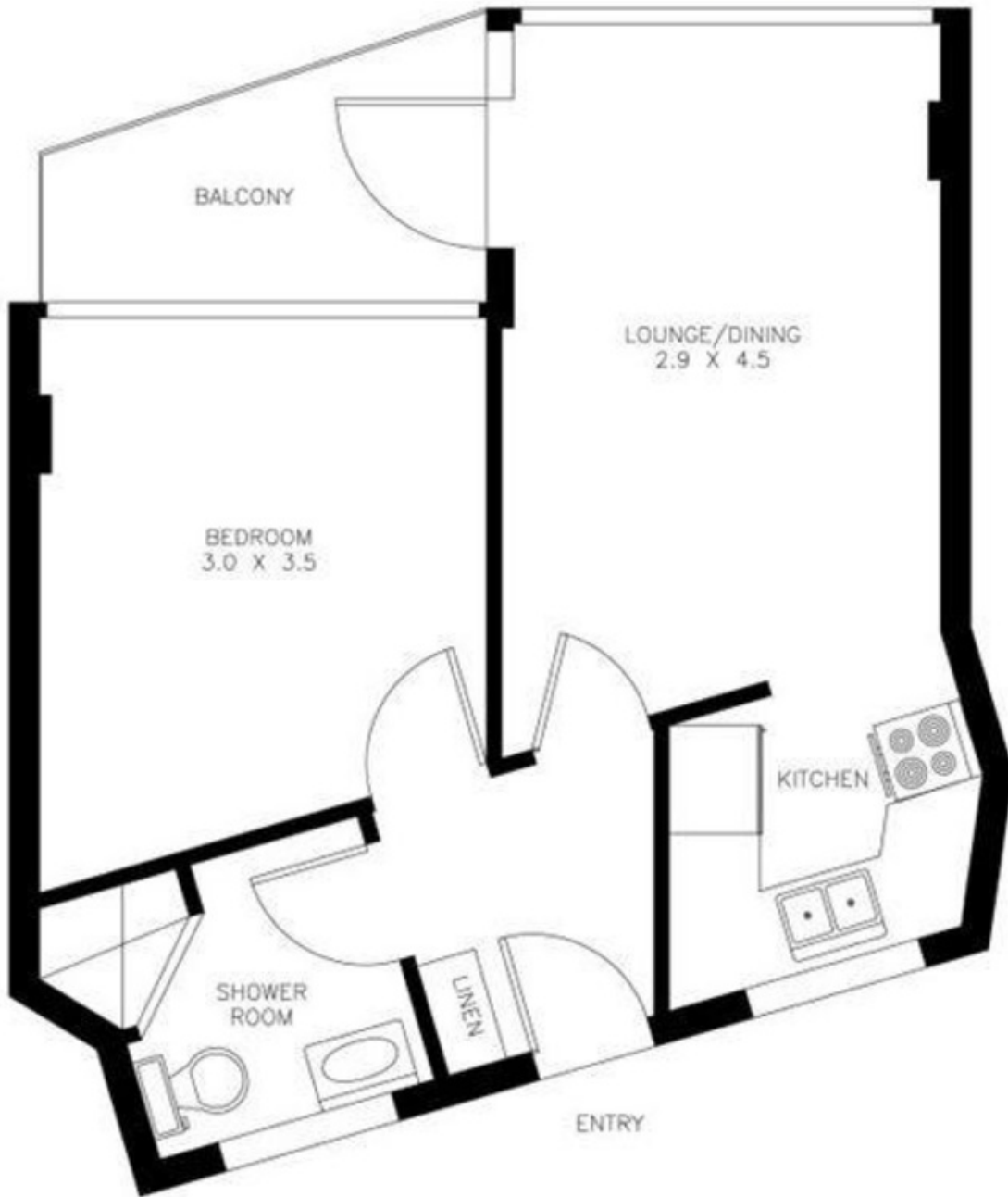

UNDERCOVER CARSPACE

14a/16-20 Hereward Street

MAROUBRA, NSW

